

Wind Turbine Lifetime Control Using Structural Health Monitoring and Prognosis

M. Hung Do* Dirk Söffker*

* Chair of Dynamics and Control, University of Duisburg-Essen, 47057
Duisburg, Germany (e-mail: {hung.do;soeffker}@uni-due.de).

Abstract: In wind energy operation and maintenance costs significantly contribute to the overall cost. This paper proposes a novel adaptive lifetime control approach for wind turbines to reduce operation and maintenance costs. The approach is based on a cascade structure with the outer loop utilizing structural health monitoring and prognosis techniques to determine suitable controller parameters and reference values of the inner loop. The trade-off between power production and load reduction is balanced to achieve predefined service lifetime using the knowledge of current system state-of-health and predicted future damage accumulation behavior. Unscheduled downtime is avoided by guaranteeing the predefined lifetime, hence reducing the maintenance cost. Simulation results using a reference wind turbine model show that the proposed control strategy can regulate the lifetime or the accumulated damage to the desired value with a reasonable sacrifice in harvested power.

Keywords: Wind Turbine, Structural Health Monitoring and Prognosis, Remaining Useful Lifetime, Structural Load, Cost of Energy, Advanced Control.

1. INTRODUCTION

Wind power is one of the most promising sustainable energy sources to replace depleting traditional fossil energy. However, the production cost of wind energy still higher than that of conventional technologies (van Kooten (2016)). To make wind energy more competitive, its cost of energy (COE) needs to be reduced either by evolution in wind turbine (WT) design, applied material or optimal operation and maintenance. Recently, advanced MIMO control approaches are applied for WTs to maximize power production and reduce structural loads. Load mitigation helps to expand the turbine lifetime, reduce the maintenance cost, and allows to build larger WTs. However, load reduction often comes with the consequence of decreasing power production and increasing blade pitch activities. Balancing and optimizing this trade-off is challenging and still is an open problem.

Wright and Balas (2003) apply a LQG observer-based controller to regulate rotor speed and reduce structural loads. The trade-off between speed regulation and power production is defined by the corresponding rows of the weighting matrix Q . An adaptive controller is proposed in Ma et al. (2015) to maximize extracted power and reduce fatigue damage. The conflict between power maximization and load mitigation is considered by designing the parameters of an internal PI controller. Stol et al. (2006) employ an individual pitch controller (IPC) to mitigate fatigue loading in both part-load and full-load region. The trade-off between competing objectives is balanced by designing weighting functions for the full-state feedback controller. Do and Söffker (2019) propose a robust observer-based control strategy for WT load mitigation. By designing

the shape of performance channels, the level of load mitigation, speed regulation, and power production can be regulated.

Generally, weighting coefficients are used to balance the trade-off between load reduction, power extraction, and control energy. The design of weights is typically trial-and-error without a systematic procedure. To optimize the trade-off, Njiri et al. (2019) integrate a system health monitoring model into the control loop to provide the current state-of-health (SoH) information. Depending on the actual health status indicated by accumulated damage level, more or less effort is put into load reduction capacity by switching between pre-calculated controllers. The proposed method can extend the service lifetime of WTs with a slight reduction in harvested power. However, due to the lack of remaining useful lifetime (RUL) and future behavior information, the method can not guarantee the predefined lifetime.

The wind turbine is a complex system, a failure in one of the WT components may lead to un-schedule downtime increasing the operation and maintenance (O&M) costs. To avoid an early failure of the system, the design lifetime of the components needs to be ensured. In this contribution, an addition lifetime control loop is integrated into the primary WT control system. Lifetime controller uses the information of historical accumulated damage, predicted damage accumulate future behavior provided by a structural health monitoring and prognosis (SHMP) model to define parameters and reference values of the primary controller. By continuously controlling the load mitigation level, the desired service lifetime can be achieved with

maximum power generation possible providing the optimal balance between power generation and load mitigation.

The paper is organized as follows: a description of wind turbine system health monitoring is outlined in section 2. In section 3, the load mitigation control strategies for the part-load region and the trade-off between power production and load reduction is explained. In section 4, the lifetime control algorithm using the lifetime prognosis information is developed and illustrated. Finally, conclusions are given.

2. WIND TURBINE HEALTH MONITORING

System health monitoring techniques provide the current system SoH and look for variation in system performance. Base on the provided information, suitable actions such as adjusting controllers or maintaining damaged components are realized to help the system working at maximum performance.

State-of-health of a system is defined by health indicator variables. For WT applications, accumulated fatigue damage is widely used as a health indicator, see Adams et al. (2011). When a repeated force is applied to a mechanical component, the component will be damaged and weakened. The damage called fatigue damage can not be reversed and produces micro-cracks in the component. When the damage accumulates to a pre-defined level, the component may be broken or reach the end of its lifetime. The lifetime of a component quantified by the number of cycles to failure N depends on the material used and the amplitude of the applied load S . For a specific material, this relation is represented as a function called S - N curve typically obtained through experiments.

Cumulative damage is often calculated using Miner rule, see Miner (1945). Assuming k different load amplitude levels, namely $S_i, (1 \leq i \leq k)$. For the whole considered load time-series, there are n_i cycles fall into group of S_i level. The number of cycles to failure at the load level S_i is N_i defined by the S - N curve. The damage accumulation D_{ac} can be expressed as

$$D_{ac} = \sum_{i=1}^k D_i = \sum_{i=1}^k \frac{n_i(S_i)}{N_i(S_i)}, \quad (1)$$

with D_i as damage increment of load level S_i and D_{ac} as accumulated damage of all load levels. The time when the damage accumulation D_{ac} reaches a predefined limit is the system service lifetime, after this time the system is considered as failed.

For arbitrary load time-series, rainflow-counting algorithm (RFC) proposed by Matsuishi and Endo (1968) is used to transform a spectrum of varying stress levels to a set of simple load levels allowing the application of Miner rule.

3. LOAD MITIGATION CONTROL

3.1 Maximum power point tracking control

Depending on wind speed, WTs operate at two main regions with distinct objectives. Part-load region (region 2) is between cut-in and rated speed. In this region, the main goal is to maximize the energy captured from the wind.

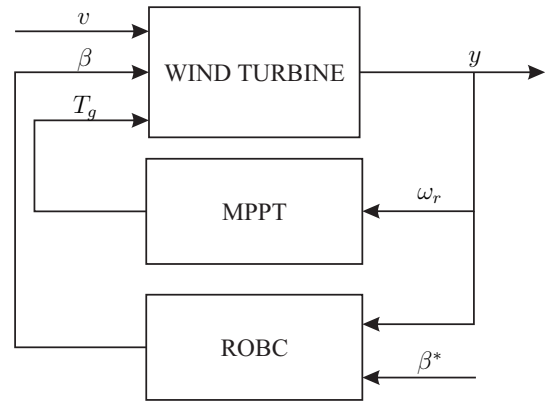

Fig. 1. WT region 2 loads mitigation control

In the full-load region (region 3), which is between rated and cut-out speed, the goal changes to regulate the power production at the rated value to guarantee the turbine operates under safety limits.

The structural load can be reduced to extend the turbine lifetime by employing MIMO controllers. The controllers realize multi objectives varying with the working situation. When the controllers try to mitigate structural load typically by modifying the blade pitch angle of the turbine, the power generation also is affected, leading to the conflict between contrary goals. The conflict needs to be systematically compromised using suitable criteria.

In this contribution, the part-load region is considered to emphasize the trade-off between maximizing power production and mitigating structural load. The WT power production depends on the turbine operating point defined by wind speed, rotor rotational speed, and blade pitch angle. The wind speed varies stochastically in nature, so to make WTs operate at the optimal point, the rotor speed and blade pitch angles need to be controlled accordingly by maximum power point tracking (MPPT) control methods. One of the most common MPPT control algorithms applied to WTs is tip-speed-ratio (TSR) control. The method maintains the optimal TSR λ^* to maximize the power coefficient C_p , which is a nonlinear function of TSR λ and blade pitch angle β . In region 2, β is held at a constant optimal value β^* that yields the maximum aerodynamic lift, so C_p depends on λ only.

Tip-speed-ratio λ is defined as the ratio between rotor speed ω_r and active wind speed v as

$$\lambda = R \frac{\omega_r}{v}. \quad (2)$$

To maintain the optimal TSR, the rotor speed ω_r needs to follow the stochastically vary wind speed v . The standard method for optimal TSR tracking is to use the generator torque T_g as control input as

$$T_g = \frac{1}{2N_g} \rho \pi R^5 \frac{C_p(\lambda^*, \beta^*)_{max}}{(\lambda^*)^3} \omega_r^2, \quad (3)$$

where N_g denotes the gearbox ratio between generator and rotor speed, ρ the air density, R the rotor radius, and $C_p(\lambda^*, \beta^*)_{max}$ the maximum power coefficient. More details are given in Johnson et al. (2004).

3.2 Load mitigation by MIMO controllers

To reduce unwanted structural load, a robust observer-based controller (ROBC) proposed by Do and Söffker (2019) is adopted in combination with the standard MPPT controller (fig.1). The ROBC controller has two objectives: to regulate the blade pitch angle at the optimal value to achieve maximum power production, and to reduce the tower vibration considered as structural load. The approach applies traditional observer-based controller (OBC).

A linearized wind turbine model operating at certain wind speed can be represented in state-space form as

$$\begin{aligned} \dot{x} &= Ax + Bu + B_d d \\ y &= Cx, \end{aligned} \quad (4)$$

where A, B, B_d, C denote the system matrix, u denotes control input which is the collective blade pitch angle, y the measured output, x the system states, and d the wind disturbance. The system states include variables representing blade, tower, drive-train variations, and the rotor speed. The measured outputs include the rotor speed, the blade pitch angle, and the tower fore-aft bending moment. The model is obtained numerically in a suitable coordinate from the WindPACT 1.5 MW nonlinear reference wind turbine, see Jonkman et al. (2005). The steady-state operating point is selected as hub-height wind speed of 8 m/s.

The formulation of the OBC can be written as

$$\begin{aligned} \dot{\hat{x}} &= (A - BK - LC)\hat{x} + Ly \\ u &= -K\hat{x}, \end{aligned} \quad (5)$$

where K and L denote controller and observer gains, \hat{x} the estimated states. The controller depends smoothly on the design matrices K and L

$$R = OBC(K, L). \quad (6)$$

The robust observer-based control (ROBC) is defined as an optimal stable OBC that minimizing the mixed-sensitivity H_∞ norm of the transfer function from the exogenous inputs to the exogenous outputs with given weighting functions. The optimization problem is formulate based on weighted mixed-sensitivity H_∞ norm $\| \cdot \|_\infty$ as

$$ROBC = R^* = \underset{R \in OBC}{\operatorname{argmin}} \left\| \begin{matrix} W_1 S \\ W_2 R S \end{matrix} \right\|_\infty, \quad (7)$$

where R denotes the controller, R^* the optimal controller, S the sensitivity function, W the weighting function, and OBC denotes a space of OBC controllers that stabilize the close-loop system. The optimization (7) is solved using the non-smooth H_∞ synthesis approach introduced by Apkarian and Noll (2006) to find the optimal robust gains K^* and L^* for ROBC. The desired robustness and performance of the closed-loop system are achieved by choosing suitable weighting functions.

The ROBC controller perturbs the blade pitch angle around the optimal value β^* to reduce the WT tower vibration as an example of structural load. Structural load reduction required additional pitch activity lead to increasing fatigue damage of the actuators. When the blade pitch is controlled around the optimal value, the WT operates at sub-optimal conditions reducing the power production. The more efforts are put into load reduction,

the more pitch activity required leads to more power contraction. This trade-off is illustrated in fig. 2.

In figure 2, the relationship between the accumulated fatigue damage and the pitch activity defined by the integration of the squared error of the real pitch angle and the optimal value is shown. In the figure, the results evaluation comparing load mitigation control (blue) with the baseline control (red) are given. The baseline control does not include the load reduction control loop. In this case, the blade pitch is constant at the optimal value, the power production is maximized by the MPPT controller, and the fatigue damage is the highest. The load reduction control results are shown for different controllers with varying load mitigation levels defined by weighting coefficients. It can be observed from the figure, the controller producing less damage shows higher pitch activity. In this case, the WT operates further from the optimal point, thus provides less energy. The maximum possible load mitigation level is limited by the actuator dynamics.

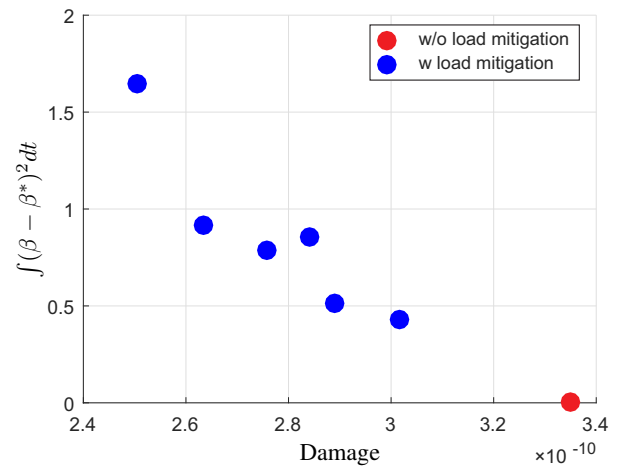

Fig. 2. Pitch activity and fatigue damage with different weights

3.3 Load mitigation by power down-regulation

To supplementary reduce the structural load, a tactical operation that can be adopted is to operate the WT at a down-scaled capacity, which has less power and fatigue damage produced. The goal of the approach is to keep the WT operate under a predefined damage threshold avoiding unscheduled downtime, see Frost et al. (2013).

In the full-load region, the tactic can be realized by regulating the generator power to below-rated value, as a result, the damage produced will be reduced accordingly. As mentioned by Njiri et al. (2019), when the generator is de-rated by 30 %, the structural load can be reduced by 36.6 %.

In the part-load region, the structural load can be reduced by tracking a sub-optimal power coefficient. In this case, the aerodynamic efficiency of the WT drops hence reduce power production and fatigue loading. Down-regulation is achieved through yaw or pitch control. For the load reduction purpose, down-regulation pitch control is typically

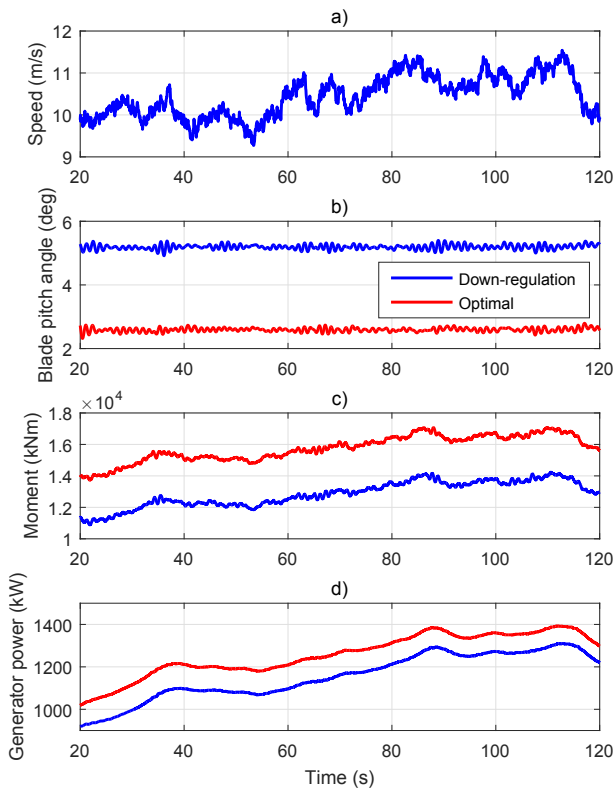

Fig. 3. WT down-regulation: a) wind speed, b) blade pitch angle, c) tower bending moment, d) generator power

done by increasing the pitch angle above the optimal value, see van der Hoek et al. (2018).

Figure 3 shows the simulation results of the down-regulation strategy for the part-load region. The simulation is done using FAST software and WindPACT 1.5 MW reference WT developed by NREL, see Jonkman et al. (2005). A stochastic wind profile is used with the mean wind speed of 10 m/s and turbulence intensity of 5 % (fig. 3.a). In the optimal case represented in red, the blade pitch is kept at the optimal angle of 2.6 deg, the generator power is maximized (fig 3.b,d). In the down-regulation case denoted by blue, the blade pitch is increased to 5.2 deg, the WT operates at the sub-optimal condition. The generator power structural load represented by the tower bending moment (fig. 3.c) is reduced with the exchange of power degradation.

It can be detected that down-regulation techniques lead to significant deterioration in harvested wind energy. Due to this trade-off, the techniques are employed only in critical situations when the load mitigation controllers mentioned in the previous section can not guarantee the normal operation.

4. LIFETIME CONTROL

The trade-off between structural load and power production can be balanced either by varying the load mitigation level of the MIMO controllers or by power down-regulation. The MIMO controllers are able to mitigate

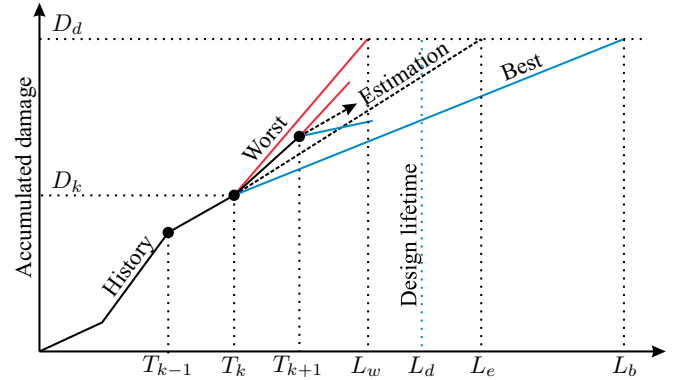

Fig. 4. WT lifetime prognosis

the structural load without a significant reduction in power generation. Still, MIMO controllers require additional pitch activity contributing to the actuator damage. Wind turbines operate in critical situations such as highly turbulent wind speed, or faulty conditions may produce extremely high damage exceeding the load mitigation capacity of controllers. In this situation, to further reduce the damage keeping the WT operates under safety limits, down-regulation needs to be applied with the exchange of power deterioration.

In this section, a novel adaptive scheme to optimal decides the load mitigation level guarantee a predefined desired lifetime is proposed. The decision-making process is based on the information of current and prognostic system SoH provided by a SHMP model.

4.1 Lifetime prognosis

The accumulated fatigue damage D_k representing the structural load at the current time step T_k by RFC and Miner rule using the measured loading data (fig. 4). The time when the accumulated damage reaches a design limit D_d is considered as the WT service lifetime. The real service lifetime is expected to be larger than a design value L_d . The design lifetime is calculated based on normal working conditions plus some safety margins.

The future trend of the accumulated damage depends on the wind speed and control system configurations. Since the future wind speed is unknown and varies stochastically, it is difficult to predict the damage accumulation behavior or the actual WT lifetime. However, a potential range of the actual future lifetime can be obtained through Monte Carlo simulation. Simulations are repeated with wind profiles and controllers defined by mean wind speed, turbulence intensity, and load mitigation level. The wind profiles can be derived from previous measured data. For simplicity, the parameters for simulations are randomly sampled from possible values (table 1). From the simulation results, the worst and the best achievable lifetime L_w and L_b can be obtained. The average estimation lifetime L_e is calculated based on the average damage accumulation rate of the logged history data. The estimated lifetime is formulated as

$$L_e = \frac{T_k}{D_k} D_d. \quad (8)$$

Table 1. Parameter ranges

Mean speed (m/s)	Turbulence intensity (%)	Load mitigation level
4-12	0-18	0-max

The estimated remaining useful lifetime at current time step T_k is calculated as

$$RUL = L_e - T_k = T_k \left(\frac{D_d}{D_k} - 1 \right). \quad (9)$$

4.2 Adaptive algorithm

To avoid unwanted downtime that increases the O&M cost, it is important to ensure every component of WT can reach the design lifetime despite changing operating conditions. An adaptive algorithm is required to decide the optimal load mitigation level that guarantees the predefined lifetime while produces energy as much as possible. The adaptive algorithm is based on the design lifetime feasible coefficient (LFC) defined as

$$LFC = \frac{L_d - L_e}{L_b - L_e}. \quad (10)$$

Depending on the value of LFC , suitable actions are realized. The possible cases are:

- (1) $LFC < 0$: this is the desired case where the estimated lifetime L_e is larger than the design lifetime L_d . Load mitigation is not needed to ensure the design lifetime, so the load mitigation level can be reduced to optimize the power production and decrease the pitch activity.
- (2) $0 < LFC \leq 1$: the design lifetime L_d is larger than the estimated L_e and lower than the best value L_b . A higher level of load mitigation is required to make L_d lower than L_e . The load reduction level can be increased by increasing the weight element corresponded to the loading output and then re-design the controller. Down-regulation is not needed for this situation, the pitch angle reference is set to the optimal value.
- (3) $LFC > 1$: the best achievable lifetime L_b is lower than the design value L_d . The load mitigations controller are not able to guarantee the desired lifetime. To further reduce the load, down-regulation action is employed by increasing the pitch angle set-point.

The control structure is shown in fig. 5. The primary control system contains the MPPT controller and the ROBC load reduction controller. The MPPT controller controls the rotor speed to track the maximum power coefficient with the assumption that the blade pitch is at the optimal angle. If the blade pitch is not optimal, the MPPT controller tracks the sub-optimal power coefficient that produces less power and fatigue damage denoted as down-regulation. The load reduction controller regulates the pitch angle around the optimal value to mitigate the structural load. The load mitigation level can be adjusted by modifying the weighting functions in the controller design step.

To maximize power production with the constraint that the WTs must reach the design lifetime, the load mitigation level need to be controlled based on the estimated

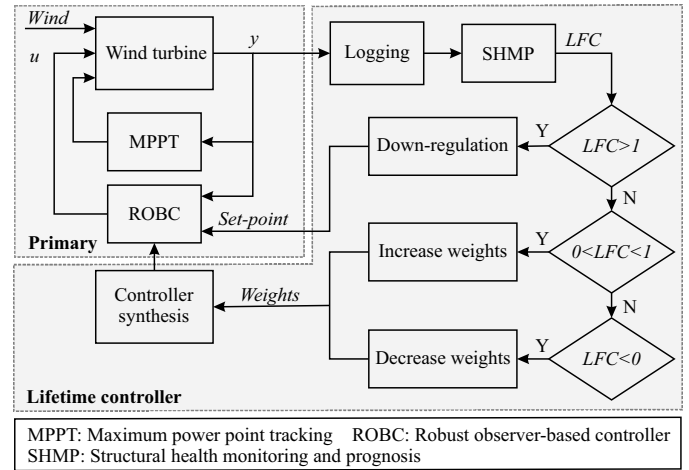

Fig. 5. Proposed adaptive lifetime control scheme

lifetime. Briefly speaking, a secondary control loop based on the information from the SHMP system defined in section 4.1 is used to control the system lifetime.

The measured values of wind speed and loading variable, here is the tower bending moment, are logged into the memory. The increased damage $\Delta D_k = D_k - D_{k-1}$ in the previous time interval from T_{k-1} to T_k at the current time step T_k is calculated from the logged data by RFC and Miner rule. Note that the damage is calculated at every time step, so only one step backward historical data is required avoiding the memory problem of the RFC algorithm (fig. 4). The time interval of the lifetime control loop is different and higher than that of the primary loop allowing real-time application. At every time step, the estimated, worst, and best lifetime is calculated based on the average, worst, and best damage accumulation rate obtained from the Monte Carlo simulations. From the prognosis data, the design lifetime feasible coefficient (LFC) is calculated. Based on the value of LFC , the secondary control loop can re-calculate parameters or modify the set-point of the primary controller regulating WT lifetime. The load mitigation level of the primary loop is continuously adjusted to the optimal value using the lifetime feedback.

4.3 Results

The proposed lifetime control scheme is illustrated by simulations using FAST software and WindPACT 1.5 MW reference WT. The wind profile used has 10 m/s mean speed and 5 % turbulence intensity (fig. 6). The objective of the lifetime controller is to generate power as much as possible while ensuring a predefined design lifetime. The time intervals of the primary and lifetime control loop are 0.001 and 10 s, respectively. The desired lifetime for illustration purpose is 600 s.

The results are shown in fig. 7 for maximizing power production, lifetime controlled, and maximizing load reduction cases. In the power maximization scenario, only MPPT controller is used without load reduction. The accumulated damage reaches the design damage before the design lifetime of 600 s leads to the risk of early failure. For maximizing load reduction case, an additional load reduction controller is used with the highest level of load mit-

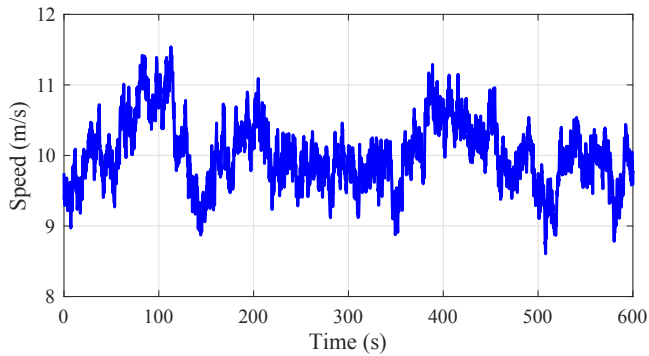

Fig. 6. Stochastic wind profile

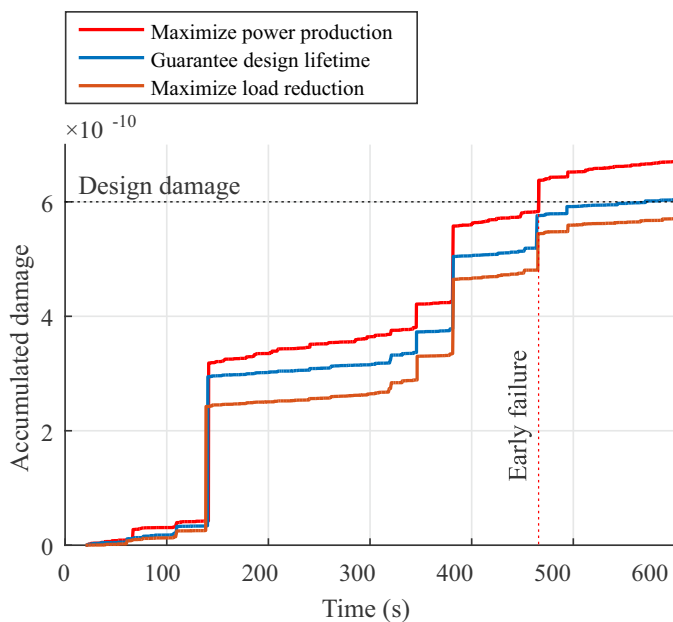

Fig. 7. Lifetime control results

igation. The WT lifetime, in this case, is higher than the design lifetime with the payment of power reduction. The lifetime control case strikes an optimal balance between power production and load mitigation. The simulation result shows that the proposed approach is able to control the system lifetime to a predefined value guaranteeing system safety while maximizing power harvested.

5. CONCLUSION

The paper proposes a novel adaptive lifetime control strategy for wind turbines. A system health monitoring and prognosis model is integrated into the control loop to provide the information of current system state-of-health and possible future lifetime. The predicted lifetime is used to adapt the parameters and references of the primary load reduction control loop. The trade-off between power production and load mitigation is optimized by regulating the WT lifetime to a predefined design value. The simulation using a high fidelity model shows that the proposed approach is able to control the lifetime of the system, thus avoiding un-scheduled downtime and decrease the operation and maintenance cost of wind turbines.

ACKNOWLEDGEMENTS

The research reported in this paper is partly supported by the Vietnam International Education Development (VIED) scholarship received by the first author for his Dr.-Ing. study at the Chair of Dynamics and Control, UDE, Germany.

REFERENCES

- Adams, D., White, J., Rumsey, M., and Farrar, C. (2011). Structural health monitoring of wind turbines: method and application to a hawt. *Wind Energy*, 14(4), 603–623.
- Apkarian, P. and Noll, D. (2006). Nonsmooth h_∞ synthesis. *IEEE Transactions on Automatic Control*, 51(1), 71–86.
- Do, M.H. and Söffker, D. (2019). Robust observer-based load extenuation control for wind turbines. In *15th International Conference on Multibody Systems, Non-linear Dynamics, and Control (MSNDC)*. ASME.
- Frost, S.A., Goebel, K., and Obrecht, L. (2013). Integrating structural health management with contingency control for wind turbines. *International Journal of Prognostics and Health Management*, 4(9), 11–20.
- Johnson, K.E., Fingersh, L.J., Balas, M.J., and Pao, L.Y. (2004). Methods for increasing region 2 power capture on a variable-speed wind turbine. *Journal of solar energy engineering*, 126(4), 1092–1100.
- Jonkman, J.M., Buhl Jr, M.L., et al. (2005). Fast user's guide. *National Renewable Energy Laboratory, Golden, CO, Technical Report No. NREL/EL-500-38230*.
- Ma, Z., Shaltout, M.L., and Chen, D. (2015). An adaptive wind turbine controller considering both the system performance and fatigue loading. *Journal of Dynamic Systems, Measurement, and Control*, 137(11), 111007.
- Matsuishi, M. and Endo, T. (1968). Fatigue of metals subjected to varying stress. *Japan Society of Mechanical Engineers, Fukuoka, Japan*, 68(2), 37–40.
- Miner, M.A. (1945). Cumulative damage in fatigue. *J. Appl. Mech.*, 12(3), A159–A164.
- Njiri, J.G., Beganovic, N., Do, M.H., and Söffker, D. (2019). Consideration of lifetime and fatigue load in wind turbine control. *Renewable energy*, 131, 818–828.
- Stol, K.A., Zhao, W., and Wright, A.D. (2006). Individual blade pitch control for the controls advanced research turbine (cart). *Journal of solar energy engineering*, 128(4), 498–505.
- van der Hoek, D., Kanev, S., and Engels, W. (2018). Comparison of down-regulation strategies for wind farm control and their effects on fatigue loads. In *2018 Annual American Control Conference (ACC)*, 3116–3121. IEEE.
- van Kooten, G.C. (2016). The economics of wind power. *Annual Review of Resource Economics*, 8, 181–205.
- Wright, A.D. and Balas, M.J. (2003). Design of state-space-based control algorithms for wind turbine speed regulation. *Journal of solar energy engineering*, 125(4), 386–395.