

Stability of a Class of Controllers for a Sequence of Canals and Structures

R.R.P. van Nooijen* A.G. Kolechkina**

* Faculty of Civil Engineering and Geosciences, Delft University of
Technology, Netherlands (r.r.p.vannooyen@tudelft.nl)

** Delft Center for Systems and Control, Delft University of
Technology, Netherlands

Abstract: Networks of open channels form an important category of environmental systems. They are used not only to transport irrigation and drainage water, but also as highways for barges transporting raw materials and goods. Automatic control of these systems poses specific problems. A local stability analysis for an open canal that is split into several parts by sluice gates under discrete time control is proposed. Theoretical justification is provided, and the method is tested for a simple controller. The method allows the examination of local stability of a series of canals when equipped with a controller from a large class, linear and non-linear. The analysis is based on the analysis of the eigenvalues of a matrix derived from the controlled system that is small enough to allow for parameter optimization.

Keywords: Environmental Systems, Water quality and quantity management, Systems with delay, Sampled data systems

1. INTRODUCTION

Networks of open channels occur everywhere, not only in irrigation and drainage systems, but also as highways for barges transporting raw materials and goods. When they are used as transport routes, it is essential to keep the water level between certain margins. If the level is too high then barges will not be able to pass under bridges; if it is too low then the barges may run aground. For irrigation and drainage canals, level control is needed to avoid over-topping of the banks. In irrigation canals the proper functioning of gates and weirs that divert water from the main canal may also depend on water level control. Finally, for canals in polders, the water level is linked to the shallow ground water level, which must be controlled to avoid damage to crops and foundations. In all these cases, only the boundary conditions at the end of canals can be controlled, and this limits what can be achieved.

As more advanced control methods such as Model Predictive Control (MPC) come into wider use for these systems (Segovia et al., 2017; Puig et al., 2005; Horváth et al., 2015; Hadid et al., 2019; Kasper et al., 2018), a clear understanding of the limits of what is possible with controllers that do not depend on predictions is essential to evaluate the trade-off between performance gains and additional complexity and cost. The physical processes in the system, both in the canals and near the actuators (weirs, sluice gates) are governed by the three dimensional Navier-Stokes equations with free surface flow. Even when simplified to a one dimensional problem, the flow in these networks is still described by sets of coupled non-linear hyperbolic partial differential equations, the one dimensional Saint-Venant or shallow water equations

(Chaudhry, 2008). The simplified model for flow through the structures is also non-linear.

Several approaches to the study of stability of controlled canals are being pursued at the moment. One is the direct study of control of the partial differential equations through their boundary conditions (Hayat and Shang, 2019; Bastin and Coron, 2016); another the approximation of a canal by a simpler model (Schuurmans et al., 1995; Litrico and Fromion, 2009). In both approaches, the controlled system is usually treated as a continuous system, and consideration of the effects of time steps associated with computer control is dealt with by assuming they are small enough not to cause problems provided proper filters are used.

In reality, these systems are sampled data systems with discrete time controllers. Moreover, the control time step used cannot be taken too small. Typical control time steps mentioned in a paper on irrigations systems to be used in benchmarking controllers are between 300 and 900 seconds (Clemmens et al., 1998). There are several reasons for this:

- The actuators themselves respond much more slowly than those of most other control systems and therefore need more time to implement control commands.
- The actuators are large, gates may be 5 to 10 meters wide, and exposed to the elements, so more subject to wear and tear.
- Maintenance is costly, especially when seen in the context of the number of actuators and typical water board budgets, and hinders operations, so limiting maintenance is important.

In this study, the focus will be on discrete time control of the water level at given locations in a canal that is split into separate reaches by sluice gates. The aim is to derive

a simplified system that can be used to study the effects of the control time step and of the delays in the system on system stability for a large class of controllers; in addition it can provide a lower bound on system performance that can be used to evaluate more advanced control schemes such as MPC and to include the effects of relatively long control time steps.

The approach chosen is to approximate the system around its operating point with a simplified non-linear process representing the canals and gates and combine this with a parametrized class of controllers that is subject to the restriction that information is shared in the upstream direction only. Next, the simplified non-linear process and controller are combined. Standard techniques from Hu and Michel (2000) are then used to derive an equivalent discrete linear system. Minimization of the eigenvalues of the corresponding matrix then provides one way to get a performance bound. The simplifications used in this paper are four-fold. Firstly, the flow is approximated by an Integrator-Delay (ID) model (Schuurmans et al., 1995; Litrico and Fromion, 2009); secondly, commensurability of sample time step, control time step, and delay is assumed; thirdly, a class of controllers is considered where only information originating from reaches downstream of the structure to be adjusted is used; and fourthly, stability is studied only locally. Commensurability is used to formulate an equivalent delay free system. Arguments that provide theoretical support for this approach will be provided. To verify that the approximations are valid the predictions of the method regarding (in)-stability for several linear controllers are tested using the Sobek 1D flow simulation software (Deltares, 2019).

2. THE PHYSICAL PROCESS

The physical process under consideration is the flow of water through a canal, for instance, the primary canal of an irrigation system that is divided into n parts called *reaches* by sluice gates called *check gates*. Part of the canal is shown in Fig. 1. At the upstream end of the canal a gate lets water into the first reach from the source of the irrigation water (a reservoir, lake, or river). The gate at the end of the last reach leads to a drainage canal. Secondary canals are connected to this canal just upstream of the check gates. The connections are called *off-takes*. The flows through these connections are controlled by sluice gates called *off-take gates* (Fig. 2). The purpose of the canal is the delivery of given flow rates at given times. In practice, control systems of gravity driven open channel irrigation systems tend to focus on water level control. There are two reasons for this:

- Over-topping of the banks of the canal is highly undesirable.
- Fluctuations of the water level directly upstream of an off-take will result in deviation from the desired flow rate until the off-take is adjusted to compensate. Moreover, these disturbances will then propagate throughout the system. It therefore desirable to control the water level in the main canal at the location of the off-take.

We assume “free flow” conditions apply and that the flow rate in the canal is such that the contribution of the kinetic

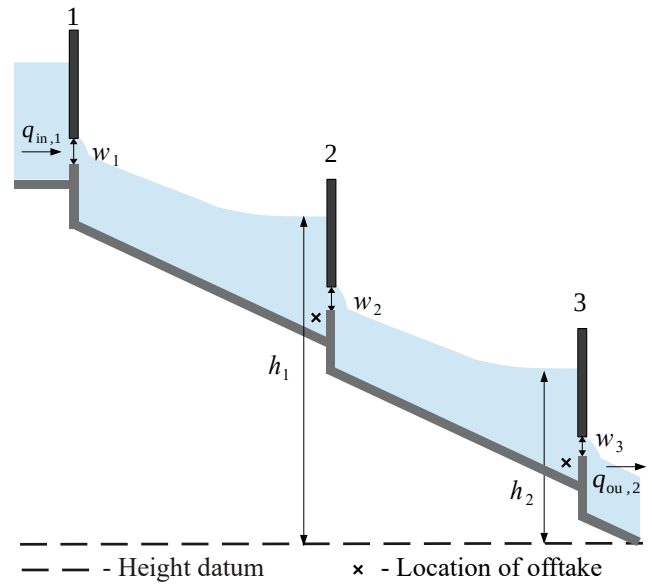

Fig. 1. Start of the primary canal

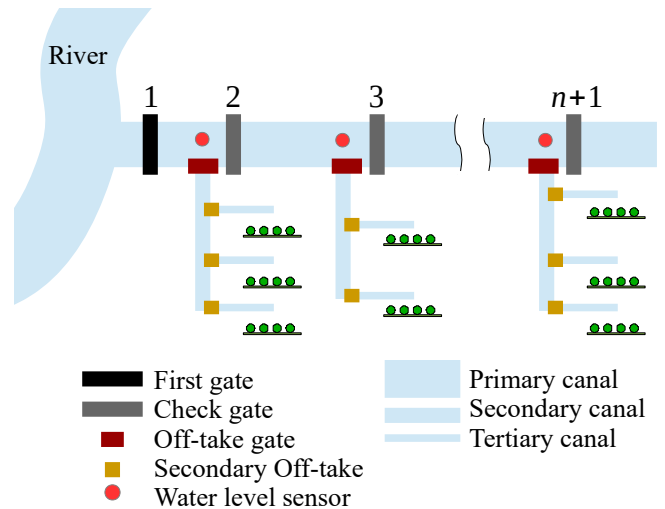

Fig. 2. Irrigation system

energy to the energy height can be neglected. For a gate with a rectangular opening and a moveable gate leaf under free flow conditions, the flow rate is given by

$$q_g(h_{up}, w) = bc_g \mu w \sqrt{2g \max(0, h_{up} - h_{sl} - \mu w)} \quad (1)$$

where h_{up} is the water level upstream of the gate; $w \geq 0$ is the height of the gate opening; h_{sl} is level of the sill of the gate opening; b is the width of the opening; c_g is a gate dependent constant; μ is the contraction coefficient, and g is the gravitational acceleration, this is approximately 9.8m/s^2 . The formula only holds as long as the upper edge of the gate leaf is sufficiently far below the upstream water surface; a rough bound is $\frac{2}{3}(h_{up} - h_{sl}) > w$ (Bos, 1989).

3. THE SYSTEM MODEL

The ID model is used for the individual reaches. For low frequency disturbances, structures in free flow, and disturbances that do not travel very far upstream, the final

model obtained will behave similarly to the model that would result from using the Integrator Delay Zero (IDZ) model for the individual reaches (Litrice and Fromion, 2009). The ID model has been tested for a variety of canals (Litrice and Fromion, 2004; Schuurmans et al., 1999; Litrice and Fromion, 2009). For the resulting linear time-invariant continuous-time process with a continuous-time controller, stability could be examined using techniques from Datko (1978) or Hale et al. (1985).

3.1 The ID model for a canal reach

The ID model represents a canal reach by a pure delay followed by an integrator, so for reach i

$$\dot{h}_i(t) = \frac{q_{in,i}(t - \tau_i) - q_{ou,i}(t)}{a_i} \quad (2)$$

where \dot{h}_i is the time derivative of the downstream water level h_i ; $q_{in,i}(t - \tau)$ is a time shifted version of $q_{in,i}$; τ_i is the delay for this reach; $q_{in,i}$ is the inflow at the upstream end of the reach; $q_{ou,i}$ is the outflow at the downstream end of the reach, and a_i is the surface area of the part of the reach where backwater effects are significant.

3.2 Moving delays within the system

Suppose a canal consisting of n reaches designed for steady state operation with starred quantities representing the steady state (equilibrium). The reaches are numbered $i = 1, 2, \dots, n$. The delay for reach i is τ_i . At equilibrium the inflow to canal i is q_i^* ; the gate opening of the gate at the upstream end of reach i is w_i^* ; the downstream depth is y_i^* ; the depth upstream of gate 1 is y_0^* ; w_{n+1}^* represents the gate opening of the gate at the downstream end of reach n , and the flow out of reach i through the off-take is $q_i^* - q_{i+1}^*$. All gates have a sill that is level with the upstream canal bottom, and there is a sufficient drop downstream of the gate to keep the gate in free flow under all circumstances. The state variable x_i is the deviation from the desired depth y_i^* , and the input variable $u_{p,i}$ is the deviation from the gate setting w_i^* . The disturbance variable d_0 is the deviation from the flow out of reach i through the off-take from $q_i^* - q_{i+1}^*$. The gate opening of the gate at the downstream end of reach n is fixed at w_{n+1}^* ; the effects of a disturbance of the gate opening can be modelled with d_n .

If each reach in the original system is replaced by a ID model of that reach, then this results in a system of Ordinary Differential Equations (ODEs). This system is shown in block diagram form in Fig. 3. Suppose all $u_{p,i}$ depend only on time. Now duplicate all gates and consider a newly created pair of gates labelled $i + 1$. It is clear that for one of the duplicates the delay τ_{i+1} can be moved from the output $q_{in,i+1}$ to the inputs x_i and $u_{p,i+1}$ as shown in Fig. 4, while the other half of the pair remains in service to deliver $q_{ou,i}$. Once this is done, it is clear that the system composed of gate $i + 1$, reach $i + 1$, and gate $i + 2$ only depends on reach i through the delayed state $x_i(t - \tau_{i+1})$ of that reach. As a consequence, as long as all $u_{p,i}$ depend only on time, we have a chain of systems connected by delays. If a new state vector is introduced consisting of time shifted versions of the individual states, then this can be rewritten as a system without delays. In the next

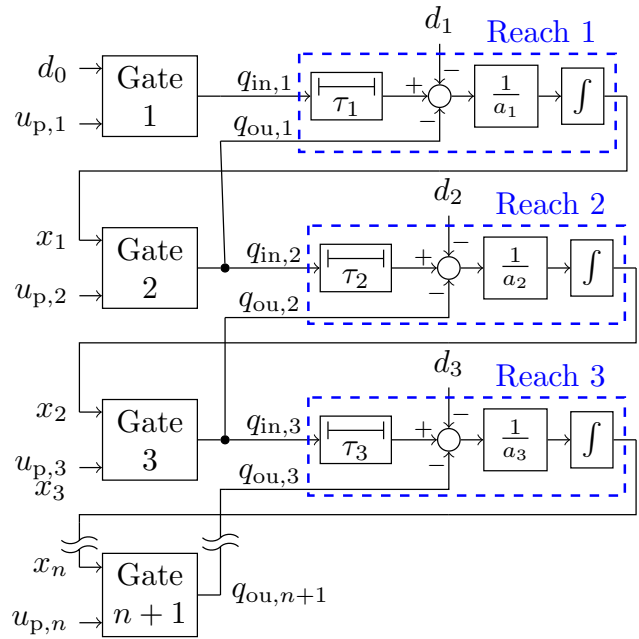

Fig. 3. Block diagram of ID reach models connected by gates in free flow

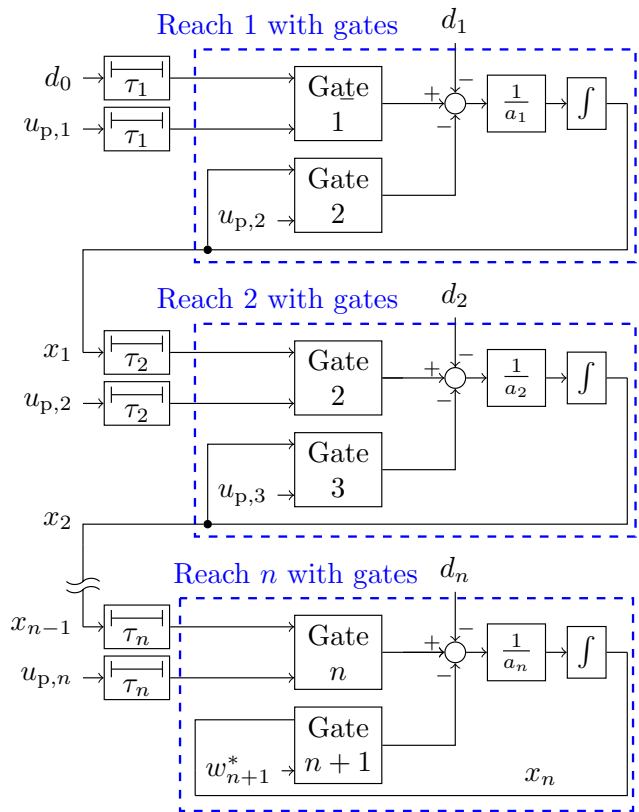

Fig. 4. Reformulated block diagram of ID reach models connected by gates in free flow

section the consequences of such a rewrite for $u_{p,i}$ that depend on the reach states will be examined.

In terms of ODEs this gives

$$\begin{aligned}\dot{x}_1 &= \frac{q_1(d_0(\cdot - \tau_1), u_{p,1}(\cdot - \tau_1)) - q_2(x_1, u_{p,2}) - d_1}{a_1} \\ \dot{x}_2 &= \frac{q_2(x_1(\cdot - \tau_2), u_{p,2}(\cdot - \tau_2)) - q_3(x_2, u_{p,3}) - d_2}{a_i} \\ &\vdots \\ \dot{x}_n &= \frac{q_n(x_{n-1}(\cdot - \tau_n), u_{p,n}(\cdot - \tau_n)) - q_{n+1}(x_n, 0) - d_n}{a_n}\end{aligned}\quad (3)$$

where a_i and τ_i are the ID model parameters for reach i and

$$q_i(\delta y, \delta w) = bc_g \mu \max(0, w_i^* + \delta w) \times \sqrt{2g \max(0, y_{i-1}^* - \mu w_i^* + \delta y - \mu \delta w)} \quad (4)$$

models the gate.

3.3 Removing the delays

The introduction of new states, inputs, and disturbances allows removal of the delays. Let

$$\mathfrak{d}_0(t) = d_i \left(t - \sum_{\nu=1}^n \tau_\nu \right) \quad (5)$$

and for $i = 1, 2, \dots, n$ define

$$\mathfrak{r}_{p,i}(t) = x_i \left(t - \sum_{\nu=i+1}^n \tau_\nu \right) \quad (6)$$

$$\mathbf{u}_i(t) = u_{p,i} \left(t - \sum_{\nu=i}^n \tau_\nu \right) \quad (7)$$

$$\mathfrak{d}_i(t) = d_i \left(t - \sum_{\nu=i+1}^n \tau_\nu \right) \quad (8)$$

It follows that

$$\begin{aligned}\dot{\mathfrak{x}}_{p,1} &= \frac{q_1(\mathfrak{d}_0, \mathbf{u}_1) - q_2(\mathfrak{r}_{p,1}, \mathbf{u}_2) - \mathfrak{d}_1}{a_1} \\ \dot{\mathfrak{x}}_{p,2} &= \frac{q_2(\mathfrak{r}_{p,1}, \mathbf{u}_2) - q_3(\mathfrak{r}_{p,2}, \mathbf{u}_3) - \mathfrak{d}_2}{a_i} \\ &\vdots \\ \dot{\mathfrak{x}}_{p,n} &= \frac{q_n(\mathfrak{r}_{p,n-1}, \mathbf{u}_n) - q_{n+1}(\mathfrak{r}_{p,n}, 0) - \mathfrak{d}_n}{a_n}\end{aligned}\quad (9)$$

This is a delay free system that can be used to reproduce the behaviour of the original system for a given \mathbf{u} , but the full system state at time t is not known until $t + \sum_{j=2}^n \tau_j$, so combining it with a general controller is not possible.

3.4 Adding a class of discrete time controllers

The method derived in this study applies to all discrete time controllers for which a linear approximation

$$x_c(k+1) = A_c x_c(k) + B_c u_c(k) \quad (10)$$

$$y_c(k) = C_c x_c(k) + D_c u_c(k) \quad (11)$$

in terms of the controller state x_c , the controller input u_c , and the controller output y_c , exists and the matrices A_c, B_c, C_c, D_c are upper triangular. Let τ_{st} be the controller time step and assume that there are N_i for $i = 1, 2, \dots, n$ such that $\tau_i = N_i \tau_{st}$ (in other words the delays are commensurate with the controller time step).

The link between the controller and the process is given by

$$u_c(k) = x(k \tau_{st}) \quad (12)$$

$$u_p(t) = y_c(k), k \tau_{st} \leq t < (k+1) \tau_{st} \quad (13)$$

If the variables \mathfrak{r} and \mathbf{u} are put into these equations then $u_c(k)$ and $y_c(k)$ can be eliminated. Just as in the case of the process, a time shifted version of the state components can be introduced

$$\mathfrak{r}_{c,i}(k) = x_{c,i} \left(k - \sum_{\nu=i+1}^n N_\nu \right) \quad (14)$$

We use (14) and (6) to rewrite (10)

$$\begin{aligned}\mathfrak{r}_{c,i}(k+1) &= \sum_{j=1}^{n_c} a_{c,i,j} \mathfrak{r}_{c,j} \left(k + \sum_{\nu=j+1}^n N_\nu - \sum_{\nu=i+1}^n N_\nu \right) \\ &+ \sum_{j=1}^n b_{c,i,j} \mathfrak{r}_{p,j} \left(k \tau_{st} + \sum_{\nu=j+1}^n \tau_\nu - \sum_{\nu=i+1}^n \tau_\nu \right)\end{aligned}\quad (15)$$

where n_c is the dimension of the controller state space, and $a_{c,i,j}, b_{c,i,j}$ are elements of the matrices A_c, B_c respectively. If A_c, B_c, C_c and D_c are zero below the diagonal then (15) can be written as

$$\begin{aligned}\mathfrak{r}_{c,i}(k+1) &= \sum_{j=1}^n a_{c,i,j} \mathfrak{r}_{c,j} \left(k - \sum_{k=i+1}^j \tau_k \right) \\ &+ \sum_{j=1}^n b_{c,i,j} \mathfrak{r}_{p,j} \left(k \tau_{st} - \sum_{k=i+1}^j \tau_k \right)\end{aligned}\quad (16)$$

and for $k \tau_{st} \leq t < (k+1) \tau_{st}$ we find

$$\begin{aligned}\mathbf{u}_i(t) &= \sum_{j=1}^n c_{c,i,j} \mathfrak{r}_{c,j} \left(k - \sum_{k=i}^j \tau_k \right) \\ &+ \sum_{j=1}^n d_{c,i,j} \mathfrak{r}_{p,j} \left(k \tau_{st} - \sum_{k=i}^j \tau_k \right)\end{aligned}\quad (17)$$

where $c_{c,i,j}, d_{c,i,j}$ are elements of the matrices C_c, D_c respectively, so the controller can be expressed in terms of $\mathfrak{r}_p, \mathbf{u}$, and \mathfrak{r}_c provided we allow delays in the controller equations.

Note that for an irrigation canal where water is supplied from upstream to meet demands downstream. It is not necessarily a serious limitation that B_c and D_c are upper triangular matrices as it still allows inclusion of all information of water levels downstream of a gate to be included in the control action that determines the flow rate through the gate. The restriction of A_c and C_c to upper triangular matrices means the controller state information available to formulate a control action for a reach is restricted to local and downstream information. Again, as long as the aim is water supply, this may not be a serious limitation.

Now, while the process description is delay free, the controller description still contains delays. For a discrete controller with a time step commensurate with the delays these delays can be removed by enlarging the state vector (Åström and Wittenmark, 1997).

3.5 Reformulating the controller

From this point on it is assumed that A_c , B_c , C_c and D_c are upper triangular. To remove the explicit delays a much longer state vector for the controller, which we will call \mathfrak{r} , is needed, but once that is defined we have a system that is free of delays. A simple, but possibly somewhat redundant, definition of $\mathfrak{r}(k)$ would be

$$\mathfrak{r}(k) = \begin{bmatrix} \mathfrak{r}_c(k) \\ \mathfrak{r}_c(k-1) \\ \vdots \\ \mathfrak{r}_c(k-M) \\ \mathfrak{r}_p(k\tau_{st}) \\ \mathfrak{r}_p([k-1]\tau_{st}) \\ \vdots \\ \mathfrak{r}_p([k-M]\tau_{st}) \end{bmatrix} \quad (18)$$

of length $n_{\mathfrak{r}} = (M+1)(n_c + n)$ where

$$M = \sum_{\nu=1}^n N_{\nu} \quad (19)$$

A smaller state is possible if the number of non-zero diagonals in the matrices is smaller than n . Next \mathfrak{r}_p and \mathfrak{r}_c are linked to \mathfrak{r} through matrices $P_c^{(a,b)} \in \mathbb{R}^{n_c \times n_{\mathfrak{r}}}$ and $P^{(a,b)} \in \mathbb{R}^{n \times n_{\mathfrak{r}}}$ given by

$$p_{c,j,\mu}^{(a,b)} = \begin{cases} 0 & j \neq \mu - n_c \sum_{\nu=a}^b N_{\nu} \\ 1 & j = \mu - n_c \sum_{\nu=a}^b N_{\nu} \end{cases} \quad (20)$$

$$p_{j,\mu}^{(a,b)} = \begin{cases} 0 & j \neq \mu - (M+1)n_c - n \sum_{\nu=a}^b N_{\nu} \\ 1 & j = \mu - (M+1)n_c - n \sum_{\nu=a}^b N_{\nu} \end{cases} \quad (21)$$

These definitions imply that

$$\mathfrak{r}_c \left(m - \sum_{k=a}^b N_k \right) = P_c^{(a,b)} \mathfrak{r}(m) \quad (22)$$

$$\mathfrak{r}_p \left(\left[m - \sum_{k=a}^b N_k \right] \tau_{st} \right) = P^{(a,b)} \mathfrak{r}(m) \quad (23)$$

The controller can now be described by

$$\mathfrak{r}_i(k+1) = \sum_{j=1}^{n_c} a_{c,i,j} \left(P_c^{(i+1,j)} \mathfrak{r}(k) \right)_j + \sum_{j=1}^n b_{c,i,j} \left(P^{(i+1,j)} \mathfrak{r}(k) \right)_j \quad (24)$$

$$\mathfrak{r}_{(j+1)n_c+i}(k+1) = \mathfrak{r}_{jn_c+i}(k+1) \quad (25)$$

$$\mathfrak{r}_{(M+1)n_c+i}(k+1) = \mathfrak{r}_p(k\tau_{st}) \quad (26)$$

$$\mathfrak{r}_{(M+1)n_c+(j+1)n+i}(k+1) = \mathfrak{r}_{(M+1)n_c+jn+i}(k+1) \quad (27)$$

$$\mathbf{u}_i(t) = \sum_{j=1}^{n_c} c_{c,i,j} \left(P_c^{(i,j)} \mathfrak{r}(k) \right)_j + \sum_{j=1}^n d_{c,i,j} \left(P^{(i,j)} \mathfrak{r}(k) \right)_j \quad (28)$$

where $k\tau_{st} \leq t < (k+1)\tau_{st}$, $i = 1, 2, \dots, n_c$ and $j = 0, 1, \dots, M-1$.

3.6 Linearisation of the gates

For $w_i^* > 0$, $y_i^* - \mu w_i^* > 0$, $u_i > -w_i^*$, $y_i^* - \mu w_i^* > \mu u_i - x_i$ a first order Taylor expansion for q_i gives

$$\begin{aligned} q_i(x_{i-1}, u_i) &= bc_g w_i^* \sqrt{2\mathfrak{g}(y_i^* - \mu w_i^*)} \\ &+ u_i bc_g \sqrt{2\mathfrak{g}(y_i^* - \mu w_i^*)} \\ &+ \frac{1}{2} bc_g w_i^* \frac{2\mathfrak{g}}{\sqrt{2\mathfrak{g}(y_i^* - \mu w_i^*)}} (x_{i-1} - \mu u_i) \\ &+ \mathcal{O}(x_{i-1}^2, u_i^2, x_{i-1}u_i) \end{aligned} \quad (29)$$

where \mathcal{O} stands for ‘order of’. This can be used to linearise (3). If we leave out the disturbance then we get

$$\dot{\mathfrak{r}}_p = A_p \mathfrak{r}_p + B_p \mathbf{u} \quad (30)$$

where $A_p \in \mathbb{R}^{n \times n}$, $B_p \in \mathbb{R}^{n \times n}$ are given by

$$a_{p,1,1} = -\frac{q_2^*}{2a_1(y_1^* - \mu w_1^*)} \quad (31)$$

$$a_{p,i,i} = -\frac{q_{i+1}^*}{2a_i(y_i^* - \mu w_{i+1}^*)} \quad (33)$$

$$b_{p,1,1} = \frac{q_1^*}{a_1} \left(\frac{1}{w_1^*} - \frac{\mu}{2(y_0^* - \mu w_1^*)} \right) \quad (34)$$

$$b_{p,i,i} = \frac{q_i^*}{a_i} \left(\frac{1}{w_i^*} - \frac{\mu}{2(y_{i-1}^* - \mu w_i^*)} \right) \quad (35)$$

$$b_{p,n,n} = \frac{q_n^*}{a_n} \left(\frac{1}{w_n^*} - \frac{\mu}{2(y_{n-1}^* - \mu w_n^*)} \right) \quad (36)$$

$$b_{p,1,2} = -\frac{q_2^*}{a_1} \left(\frac{1}{w_2^*} - \frac{\mu}{2(y_1^* - \mu w_2^*)} \right) \quad (37)$$

$$a_{p,i,i-1} = \frac{q_i^*}{2a_i(y_{i-1}^* - \mu w_i^*)} \text{ only for } i > 1 \quad (38)$$

$$b_{p,i,i+1} = -\frac{q_{i+1}^*}{a_i} \left(\frac{1}{w_{i+1}^*} - \frac{\mu}{2(y_i^* - \mu w_{i+1}^*)} \right) \text{ only for } i < n \quad (39)$$

where $i = 1, 2, \dots, n$ and $q_i^* = q_i(0, 0)$. If the controller is linear and purely proportional with D_c upper triangular, then for $k\tau_{st} \leq t < (k+1)\tau_{st}$

$$\mathbf{u}_i(t) = \sum_{j=i}^n d_{c,i,j} \mathfrak{r}_{j,p} \left(\left[k - \sum_{\nu=i}^j N_{\nu} \right] \tau_{st} \right) \quad (40)$$

which for $N_n > 0$ can be constructed from

$$\mathfrak{r}(k) = \begin{bmatrix} \mathfrak{r}_p([k-1]\tau_{st}) \\ \vdots \\ \mathfrak{r}_p([k-M]\tau_{st}) \end{bmatrix} \quad (41)$$

The time evolution \mathfrak{r} is then given by

$$\mathfrak{r}(k+1) = \Gamma \mathfrak{r}(k) + \int_{t=0}^{\tau_{st}} \exp(A_p t) dt \cdot B_p W \mathfrak{r}(k) \quad (42)$$

with

$$\Gamma = \begin{bmatrix} \exp(A_p \tau_{st}) & 0_{n \times n} & \cdots & 0_{n \times n} & 0_{n \times n} \\ I_n & 0_{n \times n} & & \vdots & \vdots \\ 0_{n \times n} & I_n & \ddots & \vdots & \vdots \\ \vdots & \ddots & \ddots & 0_{n \times n} & 0_{n \times n} \\ 0_{n \times n} & & & I_n & 0_{n \times n} \end{bmatrix} \quad (43)$$

and the elements w_{ij} of W follow from

$$\begin{aligned} u_i(k\tau_{st}) &= \sum_{j=i}^n d_{c,i,j} \mathfrak{r}_{p,j} \left(\left[k - \sum_{\nu=i}^j N_\nu \right] \tau_{st} \right) \\ &= \sum_{j=i}^n d_{c,i,j} \sum_{\mu=1}^{n_\zeta} p_{j,\mu}^{(i,j)} \mathfrak{r}_\mu(k) \\ &= \sum_{\mu=1}^{n_\zeta} w_{i,\mu} \mathfrak{r}_\mu(k) \end{aligned} \quad (44)$$

and $w_{ij} = 0$ for $i > n$ or $j > n$.

4. STABILITY THEOREMS

Even though in this paper the sample time step is fixed, the theorems from Hu and Michel (2000) are needed because of the non-linear response of the controller to the control action. If this non-linearity were not present, then the theorems from Michel et al. (2015) or other sources could be used.

Consider the hybrid system

$$\dot{x}(t) = f(x(t), x(\tau_k), u(\tau_k)), k\tau_{st} \leq t < (k+1)\tau_{st} \quad (45)$$

$$u(\tau_{k+1}) = g(x(\tau_k), u(\tau_k)), k \in \mathbb{N} \quad (46)$$

where $x(t) \in \mathbb{R}^n$, $u(t) \in \mathbb{R}^m$, $f \in C^1(\mathbb{R}^n \times \mathbb{R}^n \times \mathbb{R}^m, \mathbb{R}^n)$, $f(0,0,0) = 0$, $g \in C^1(\mathbb{R}^n \times \mathbb{R}^m, \mathbb{R}^m)$, $g(0,0) = 0$. With

$$\begin{aligned} A &= \left. \frac{\partial f(x, v, u)}{\partial x} \right|_{(0,0,0)}, A_0 = \left. \frac{\partial f(x, v, u)}{\partial v} \right|_{(0,0,0)} \\ B &= \left. \frac{\partial f(x, v, u)}{\partial u} \right|_{(0,0,0)} \\ C &= \left. \frac{\partial g(x, u)}{\partial x} \right|_{(0,0)}, D = \left. \frac{\partial g(x, u)}{\partial u} \right|_{(0,0)} \end{aligned}$$

linearise round the origin then for $k\tau_{st} \leq t < (k+1)\tau_{st}$

$$\dot{x}(t) = Ax(t) + A_0x(\tau_k) + Bu(\tau_k) + F(x(t), x(\tau_k), u(\tau_k))$$

$$u(\tau_{k+1}) = Cx(\tau_k) + Du(\tau_k) + G(x(\tau_k), u(\tau_k)), k \in \mathbb{N}$$

with

$$F \in C(\mathbb{R}^n \times \mathbb{R}^n \times \mathbb{R}^m, \mathbb{R}^n), G \in C(\mathbb{R}^n \times \mathbb{R}^m, \mathbb{R}^m)$$

$$\begin{aligned} \lim_{(x,v,u) \rightarrow (0,0,0)} \frac{F(x, v, u)}{\sqrt{\|x\|_2^2 + \|v\|_2^2 + \|u\|_2^2}} &= 0 \\ \lim_{(x,v,u) \rightarrow (0,0,0)} \frac{G(x, u)}{\sqrt{\|x\|_2^2 + \|u\|_2^2}} &= 0 \end{aligned}$$

where $\|\cdot\|_2$ is the Euclidean vector norm. Furthermore define matrix

$$H = \begin{bmatrix} \Gamma & \int_{t=0}^{\tau_{st}} \exp(At) dt \cdot B \\ D & C \end{bmatrix} \quad (47)$$

where $\Gamma = \{\exp(A\tau_{st}) + \int_{t=0}^{\tau_{st}} \exp(At) dt \cdot A_0\}$. The following theorems hold. For matrices $\|\cdot\|$ is the matrix norm induced by the Euclidean vector norm.

Theorem 1. If H given in (47) is Schur stable then the trivial solution $(x, u) = (0, 0)$ of (45) and (46) is exponentially stable. This follows immediately from Hu and Michel (2000, Theorem 2.1).

Theorem 2. If the matrix H given in (47) is invertible and $\|H^{-1}\| < 1$ then the trivial solution $(x, u) = (0, 0)$ of (45) and (46) is unstable. This follows immediately from Michel et al. (2015, Theorem 2.5).

For a small region around an equilibrium Theorem 1 now provides us with a stability test for our system. The question is whether or not this can be put to practical use. Theorem 2 does not apply directly, but it suggests that not meeting the conditions of Theorem 1 is likely to lead to instability. Our hypothesis is that the matrix H defined in (47), when set up for the system resulting from the elimination of delays and linearization of the gates, provides a good indication of stability in practice.

5. COMPUTER EXPERIMENTS AND RESULTS

Experiments were performed to test the hypothesis that the matrix H defined in (47) can be used to evaluate the stability of a canal system. While the theory behind the method applies to a large class of controllers, the connection would be easiest to see for a one parameter class of controllers. The method was applied to a system with discrete proportional controllers for a series of identical reaches separated by sluice gates in an irrigation canal. It consisted of 5 copies of reach 5 of canal 1 in the flow state corresponding to test 1 as defined in Clemmens et al. (1998). We used gates of width $b = 1.2$ m, $\mu = 1$, $c_g = 1$, a set-point of 0.9 m for the depth 7.5 m upstream of the tail end of each reach, and a time step $\tau_{st} = 300$ s. The sill of the gates is level with the bottom of the upstream canal and there is a drop of one meter just after the gate. The parameters for the ID model can be found in Litrico and Fromion (2004): $a = 817.2$ m², $\tau = 792.9$ s for an inflow of 0.4 m³/s. We used $\tau_{st} = 300$ s in our tests, the delay was rounded up to 900 s to keep commensurability. To allow use of multiple copies of this canal section, the off-take flows were set to zero. A fixed depth of 0.9 m was assumed upstream of the gate that supplies water to the first reach. A fixed gate setting corresponding to a flow of 0.4 m³/s when the water level is at set-point was imposed on the gate at the downstream end of the last reach. To examine the controller response a pulse of 0.1 m³/s of 600 s was applied to the off-take of the second canal.

Let Λ_H be the set of eigenvalues of H ; let $H(D_c)$ be the matrix H for a proportional controller with a given matrix D_c . We can now define

$$\gamma(D_c) = \max_{\lambda \in \Lambda_{H(D_c)}} |\lambda| \quad (48)$$

For a canal with five reaches the following runs were performed:

- Runs with $D_c = \beta I$ for different values of β , and the corresponding system responses are shown in Fig. 5(a-f). An overview of the relation between β and $\gamma(\beta I)$ with γ as in (48) is given in Fig. 5(h). The system

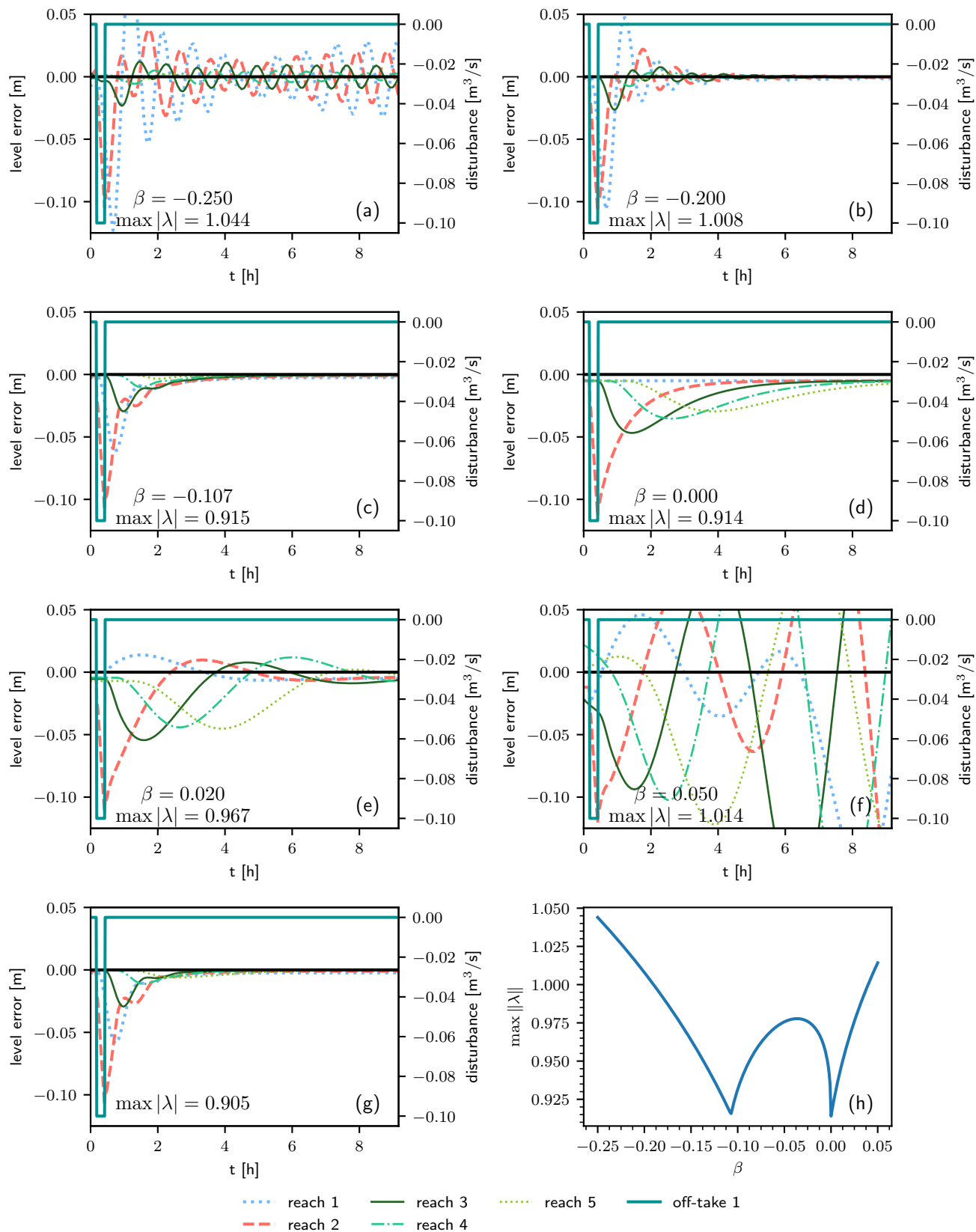

Fig. 5. System response (a-g) and parameter dependence of $\gamma(\beta I)$ (h).

response for $\beta = 0$, see Fig. 5(d), shows that fixed gates also act as controllers. There is also a slight deviation from setpoint, this is due to the difference in water level between the set point location and the gate due to the backwater curve. The system responses for $\beta = -0.107$ and $\beta = 0$ show that similar values for $\gamma(D_c)$ may correspond to very different system behaviour, see Fig. 5(c) and 5(d). There is a good correspondence between the system behaviour and $\gamma(\beta I)$; if this value is smaller than one, then the system is asymptotically stable in all cases.

- A run with proportional control by a diagonal matrix D_c such that (48) is close to minimal is shown in Fig. 5(g). The diagonal elements are $d_{c,11} = -0.10550775$, $d_{c,22} = -0.100841$, $d_{c,33} = -0.11264869$, $d_{c,44} = -0.03189222$, $d_{c,55} = 0.00066596$. The result is comparable to that for $D_c = -0.107 \times I$ shown in Fig. 5(c).

6. CONCLUSIONS

A method to examine stability of a class of discrete-time controllers for a canal consisting of reaches separated by controlled free flowing gates was presented. The method can be applied as long as the ID approximation for the reaches hold. Theoretical arguments that show the method provides sufficient conditions for local stability were given. Numerical experiments using 1D hydrodynamic simulation software for a limited subclass of controllers showed that the conditions are probably close to necessary as well.

Replacement of the gates by weirs presents no problems. The use of more complex linear or non-linear controllers is also possible and opens up the possibility of the study of the stability of series of canals with more effective controllers and to determine lower bounds on controller performance. The use of time shifted state components is particularly useful when the controller only links two or three reaches, in that case the final matrix H can be much smaller than the upper bound M given in (19).

REFERENCES

- Åström, K.J. and Wittenmark, B. (1997). *Computer-Controlled Systems: Theory and Design*. Prentice Hall, third edition.
- Bastin, G. and Coron, J.M. (2016). *Stability and boundary stabilization of 1-d hyperbolic systems*, volume 88. Springer.
- Bos, M.G. (ed.) (1989). *Discharge Measurement Structures*. International Institute for Land Reclamation and Improvement, Wageningen, Netherlands, third edition.
- Chaudhry, M.H. (2008). *Open-Channel Flow*. Springer Science+Business Media, New York, second edition.
- Clemmens, A.J., Kacerek, T.F., Grawitz, B., and Schuurmans, W. (1998). Test cases for canal control algorithms. *Journal of Irrigation and Drainage Engineering*, 124(1), 23–30.
- Datko, R. (1978). A procedure for determination of the exponential stability of certain differential-difference equations. *Q. Appl. Math.*, 36, 279–292.
- Deltares (2019). D-Flow 1D in Delta Shell: User manual. Technical report, Deltares. Released for SOBEK Suite 3.7.
- Hadid, B., Duviella, E., Chiron, P., and Archimède, B. (2019). A flood mitigation control strategy based on the estimation of hydrographs and volume dispatching. *IFAC-PapersOnLine*, 52(23), 17–22.
- Hale, J.K., Infante, E.F., and Tsen, F.S.P. (1985). Stability in linear delay equations. *J. Math. Anal. Appl.*, 105(2), 533–555.
- Hayat, A. and Shang, P. (2019). A quadratic Lyapunov function for Saint-Venant equations with arbitrary friction and space-varying slope. *Automatica*, 100, 52 – 60.
- Horváth, K., Rajaoarisoa, L., Duviella, E., Blesa, J., Petreczky, M., and Chuquet, K. (2015). Enhancing inland navigation by model predictive control of water levels: The Cunchy-Fontinettes case. In C. Ocampo-Martinez and R.R. Negenborn (eds.), *Transport of Water versus Transport over Water: Exploring the Dynamic Interplay of Transport and Water*, 211–234. Springer International Publishing, Cham.
- Hu, B. and Michel, A.N. (2000). Stability analysis of digital feedback control systems with time-varying sampling periods. *Automatica*, 36(6), 897 – 905.
- Kasper, J., Pranner, G., Simons, F., Denhard, M., and Thorenz, C. (2018). Enhancing automated water level control at navigable waterways by high-resolution weather predictions. *EPiC Series in Engineering*, 3, 1022–1029.
- Litrico, X. and Fromion, V. (2004). Simplified modeling of irrigation canals for controller design. *Journal of Irrigation and Drainage Engineering*, 130(5), 373–383.
- Litrico, X. and Fromion, V. (2009). *Modeling and Control of Hydrosystems*. Springer, London.
- Michel, A.N., Hou, L., and Liu, D. (2015). *Stability of dynamical systems*. Systems & Control: Foundations & Applications. Birkhäuser/Springer, second edition.
- Puig, V., Quevedo, J., Escobet, T., Charbonnaud, P., and Duviella, E. (2005). Identification and control of an open-flow canal using LPV models. In *Proceedings of the 44th IEEE Conference on Decision and Control and the 2005 European Control Conference. (CDC-ECC '05)*, 1893 – 1898.
- Schuermans, J., Bosgra, O.H., and Brouwer, R. (1995). Open-channel flow model approximation for controller design. *Applied Mathematical Modelling*, 19, 525–530.
- Schuermans, J., Clemmens, A.J., Dijkstra, S., Hof, A., and Brouwer, R. (1999). Modeling of irrigation and drainage canals for controller design. *Journal of Irrigation and Drainage Engineering*, 125(6), 338–344.
- Segovia, P., Rajaoarisoa, L., Nejari, F., Puig, V., and Duviella, E. (2017). Decentralized control of inland navigation networks with distributaries: Application to navigation canals in the north of France. In *2017 American Control Conference (ACC)*, 3341–3346.